

HIGH TORQUE HYBRID STEPPING MOTOR SPECIFICATIONS

General specifications	
Step Angle (°)	1.8
Temperature Rise (°C)	80 Max (rated current, 2 phase on)
Ambient Temperature (°C)	-20 ~ +50
Number of Phase	2
Insulation Resistance (MΩ)	100 Min (500VDC)
Insulation Class	Class B
Max.radial force (N)	75 (20mm from the flange)
Max.axial force (N)	15

PHASE	STEP ANGLE	CONNECTION STYLE	CURRENT	RESISTANCE	INDUCTANCE	HOLDING TORQUE	ROTOR INERTIA	WEIGHT
	DEG/STEP		A	ohms	mH	N.m	gcm ²	Kg
4	1.88	Parallel	4	0.5	1.6	1.89	480	1.0
		Series	2	2.0	6.4			
		Unipolar	2.8	1.0	1.6	1.4		

● Wiring Diagram :

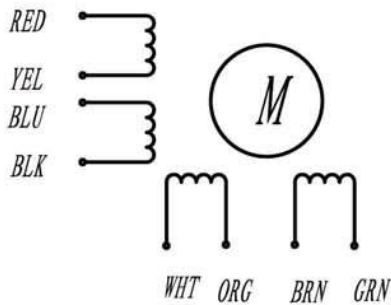

● Dimensions:
(unit=mm)

● Pull out torque curve :

VOLTAGE: 30VDC, CONSTANT CURRENT:2.1A, HALF STEP(series)

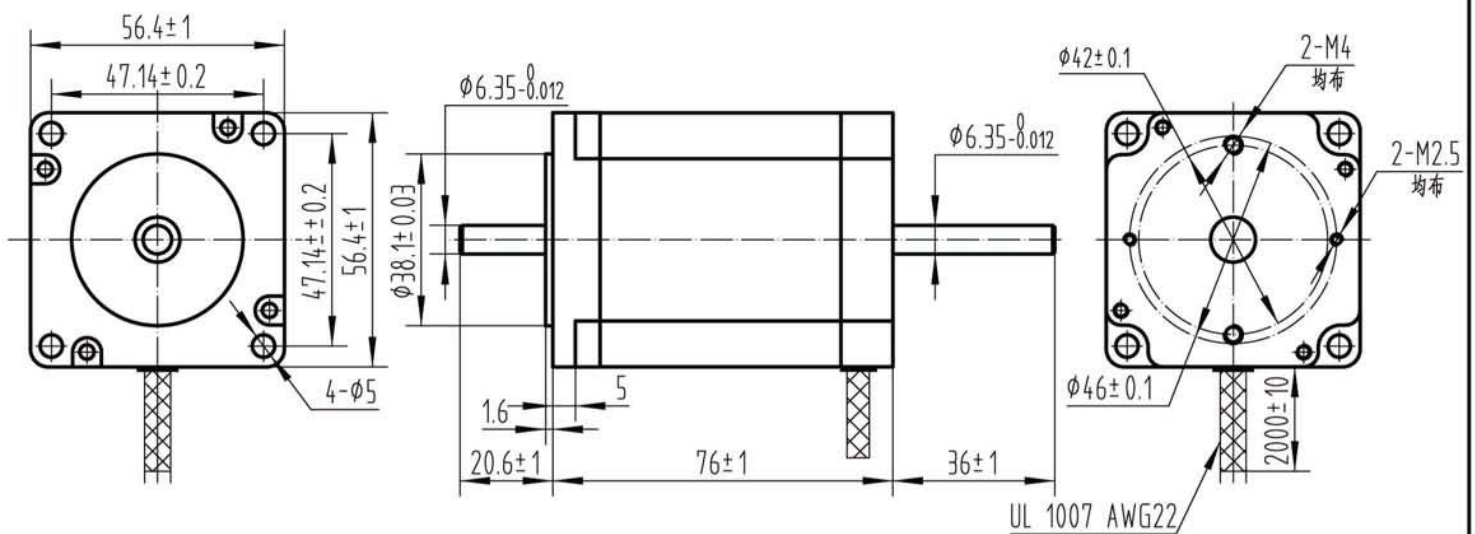
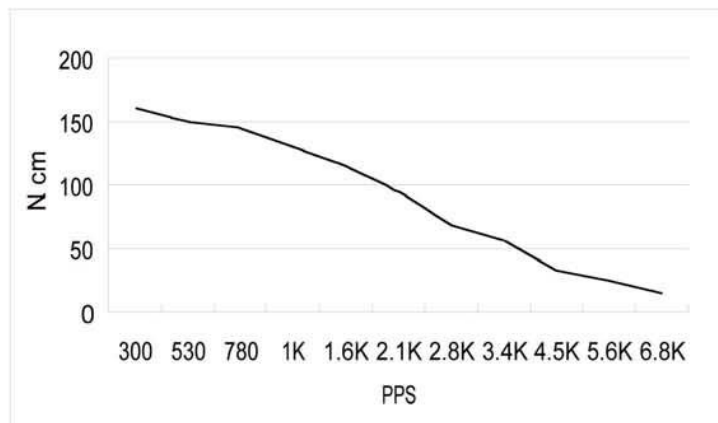

REV	REVISIONS	DESCRIPTION	BY	DATE
DRAW	王凯	2009.01.22		
CHECK				
APPROVE				

23-SH76-042-8W-6.35-3.35-1.9
léptetőmotor

M & V Elektronika Kft.
www.hobbycnc.hu

